

UHF Guitar Wireless System

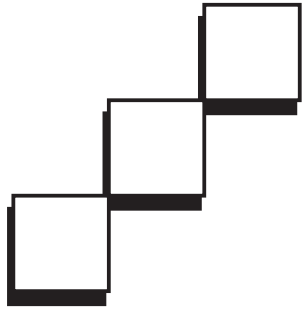

Baomic[®]
BM-5

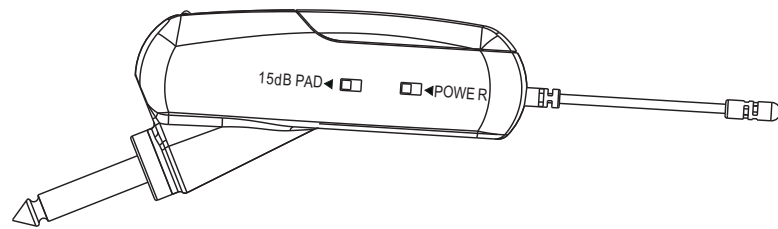

operation manual

*Before using the machine please
read this owner's manual*

PROFESSIONAL
UHF Guitar Wireless System



Declaration:

This equipment is wireless electronic products, it can generate, uses and radiate wireless frequency energy, if not installed and used in accordance with instructions contained in this manual, may cause harmful interference to wireless products communications, please use it in accordance with the local statute. We will provide a number of products with different frequencies, please choose the right one which complies the local requirement. We will take no responsibilities if any problem caused by breaking local statutes.

However, there is no guarantee that interference will not occur in a particular installation. If it happens, the user is encouraged to try to correct the interference by one or more following measures:

- RECREIENT OR RELOCATE THE RECEIVING ANTENNA
- CHANGE THE WORKING FREQUENCY
- CHECK THE SURRODING TO SEE IF ANY SAME OR SIMILAR FREQUENCY IS WORKING
- CONSULT THE DEALER OR EXPERIENCED AUDIO TECHNICIAN

Copyright:

This manual is copyrighted with all rights reserved. No portion of this manual may be copied or reproduced by all means. Besides, all specifications and information is only for reference, we will not inform if updated.

Noted:

- Avoid putting the receiver in a blind angle to make sure the sign al receiving in good condition
- Please don't throw, fall, flap, toss while it is working in case of damages.
- The machine is not waterpro of, you must avoid dropping it into water or suffering rains .
- Please keep the machine from direct sunshine and put it in a place as far as possible from the magnetic field.
- Please insert the battery with the right polarity, and must take out the battery out of the tran smitter if not use for time in case of leaking .
- Pull out the AC adapter after using the receiver.
- When replace a battery, please turn off the tran smitter first.
- Don't open it by yourself, may the high voltage will hurt you.
- There is no refit component exists, please do not open the receiver, or you will lose the right of repairing.
- Use the soft cloth to clea n the machine, when something hard to clea n, you can use the neutral scour, but must not use the volatized gasoline or thinner.

● FAQ

- 1.Receiver can't be turned on: Check the DC power connection, adaptor or batteries.
 - 2.No Audio output: Check the audio cable connection.
 - 3.Transmitter can't be turned on: Check or replace a battery
 - 4.The frequency can't be matched: Switch another channel, and retry the frequency scan.
- Any other problems please consult the distributor to problem solving.

SYSTEM COMPOSITION	
1.Receiver.....	x1
2.Guitar transmitter.....	x1
3.Audio cable.....	x1
4.Power Adapter.....	x1
5.Receiver battery1.5V AA.....	x2
6.Transmitter battery1.5V AAA....	x1
6.Operation manual.....	x1

Technique specification

1. RECEIVER:

Frequency Range	600MHz-870MHz
Modulation Type	F3E
OSC(Oscillator)System	PLL circuit.
Operating Distance	100M(receiver in sight)
De-emphasis	50u/sec
Operating Temperature	0°C - +50°C
Storage Temperature	-20°C - +70°C
Receiving Sensitivity	Sinad>30dB 10dBuV
Squelch Sensitivity	17dBuV4dBuV
S/N Ratio	(f1KHz=1mV) 95dB(A)
Audio Output Level at div.f15 KHz	(F40KHz)800mV
Audio Frequency Response	50Hz - 20KHz 3dB
THD(at SG output 56 dBuv)	(f1KHz)<0.8%
Output Impedance	5K - 10K ohms
Power	DC9V/ 3V AA
Current Consumption	9V/60mA 3V/100mA
Antenna	Dual 1/4 wave length rod antennas
Controls	Audio level volume, Channel select switch, ACT key
Display	ACT SEND(white), Power(red), Low Power(orange), single(green)

2. TRANSMITTER:

RF Output Power	10dBm1dBm
Spurious	-50dBm
Modulation Factor	40KHz
Pre- emphasis	50usec
Maximum Input Level	+2dBV
Input Impedance	20K ohms
THD	<0.8% (1KHz 100mV)
Audio Frequency Response	50Hz-20KHz 3dB
Operating Power Voltage	1.5V Typical, 1.1V Min, 2.0V MAX
Current Consumption	80mA
Battery Life	8 Hours (AAA Size battery)
Antenna	Permanently attached 1/4 wave length wire
Controls	Power Switch, 15dB Pad Switch
Indicators	Power On(LED Flash), Low Battery (LED ON when battery less than 1.1V), ACT(LED Flash)

CONTENT

Brief Introduction	3
Main Features	3-5
Installment and Operation	6-8
Technique specification	9
FAQ	10

Brief Introduction:

The traditional way of using electric guitar is by a audio cable connect the guitar to audio mixer or amplifier to transmit the audio signals, for this reason, it is restricted the guitar player's moving area on the stage. For solving this problem, our company has been designed and developed a new model which transmit and receive audio signals by frequencies-the wireless guitar transmit system. We adopt multi high frequencies, multiple noise detect and control etc skills, and it is completely solved the restrictions of the guitar players on the stage. They can walk anywhere without a long cable and have fun with audience. This product is warmly popular by musicians as soon as it promoted.

Main Features:

- Using UHF 600-870 MHz band to avert frequency interference.
- Automatic frequency scan feature searches for available frequencies.
- PLL system. preset 16 non-interfered channels.
- Using Surface Amount Technology for PCB, more stable function.
- Using the latest high frequency filter of the RF, to avoid the outside signal interference.
- Using twice mixer high frequency circuit design, very strong sensitivity.
- Special design commanding circuit, strongly improve S/N ratio.
- The receiver support DC power supply and AA batteries.
- High efficiency batteries consumption design, the transmitter can continuously use for 8hours (AAA Battery.)
- Longest distance in open: 100m, Ideal distance in open: 60m.
- It is suitable for guitar player usage.

6. Take the transmitter 'IR' window near to the receiver 'IR' window, push the 'Infrared ray transmit button' to scan the frequency. (Pic 1)

Note: When the LED 'RX' lighting, it means auto-scan done. And the machine will work in 20 seconds.

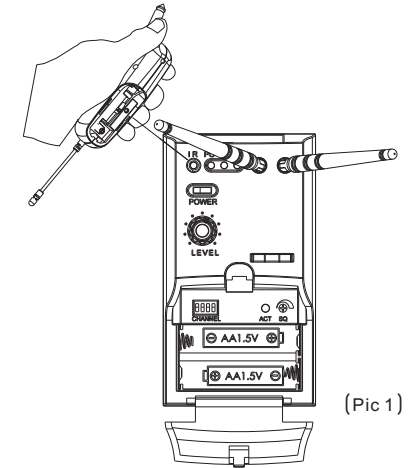

7. Insert the transmitter plug into the guitar jack, then you can play the guitar. (Pic 2)

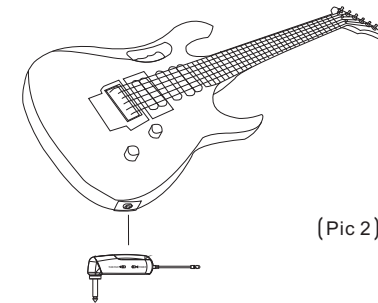

2. Connect the audio cable to the OUTPUT jack (unbalanced jack) (Pic 1)

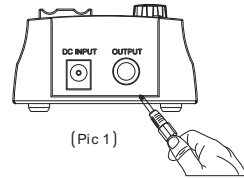

(Pic 1)

3. Turn on the power switch, the receiver works when the LED indicator lighting (Pic 2)

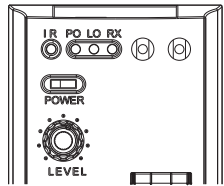

(Pic 2)

4. Open the battery cover of the receiver, select one frequency by switch (preset 16 channels), and don't close the battery cover. (Pic 3)

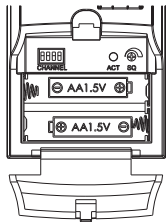

(Pic 3)

5. Open the battery cover of the transmitter, insert one 1.5V AAA battery, turn on the power switch, the transmitter works when the 'RX' LED lighting, don't close the battery cover. (Pic 4)

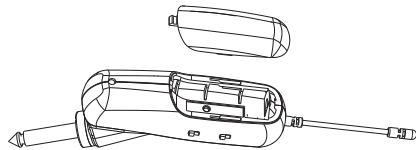

(Pic 4)

● Receiver

1. Power Switch (control the power on/off)
2. Level Control (adjust the volume)
3. Battery cover
4. Antennas (allows full rotation for picking better signals, and can be folded inward for stock convenience)
5. Signal LED (indicate the signal receiving status)
6. Power Low LED (warn low power supply)
7. Power LED (indicate the receiver ON/OFF)
8. Infrared Transmit window (auto-scan frequencies)
9. Switchable Frequency Select (16 pre-set channels)

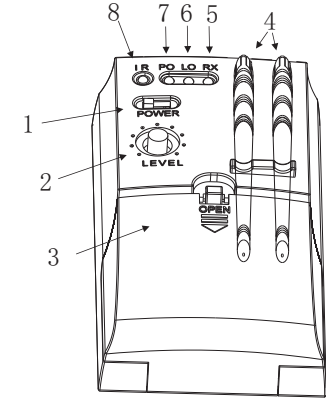

10. Squelch Adjust (adjust by screwdriver)
11. Infrared ray transmit button (push this button, then transmitter autoscan the right frequency)
12. Battery Compartment (2 × 1.5V AA batteries)

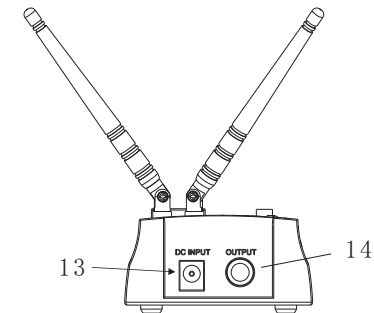
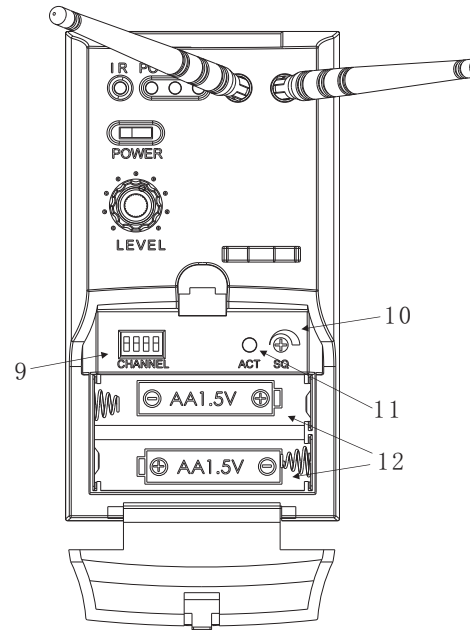

13. DC Input (DC power jack)
14. Output Jack (connect the audio cable)

● Guitar Transmitter

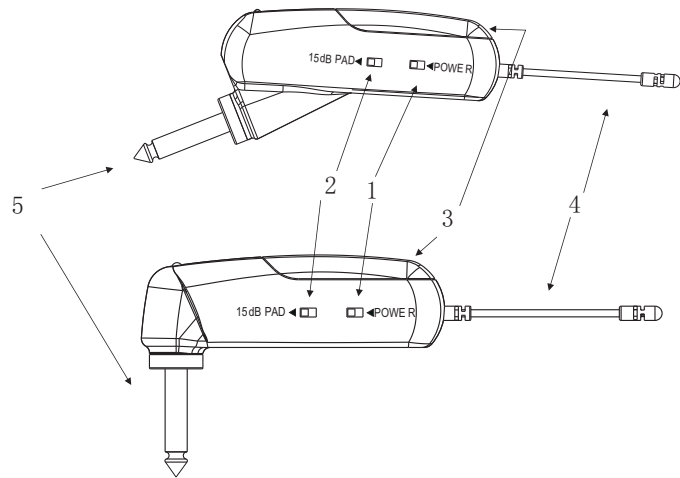

- 1.Power Switch(control the power on/off)
- 2.15dB Pad(reduce the output by 15dB when too strong signal)
- 3.Battery Cover
- 4.Antenna
- 5.Plug(connect the guitar jack)
- 6.Infrared Transmit window(auto-scan frequencies)
- 7.Battery Compartment(1×1.5V AAA battery)

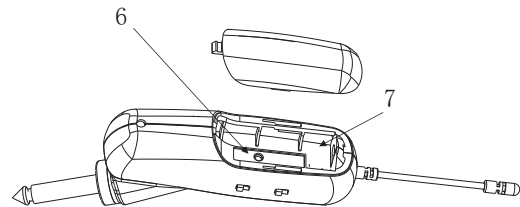

● Installation

- 1.One meter higher from the floor
- 2.One meter away from the corner

(Pic 1)

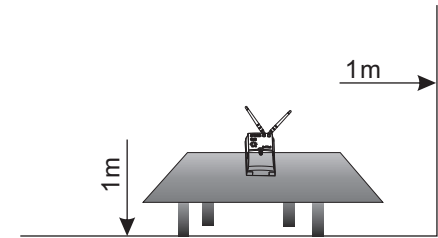

(Pic 1)

● Operation

- 1.Open the battery compartment of the receiver, put two AA batteries (note the polarity)

(Pic 2)

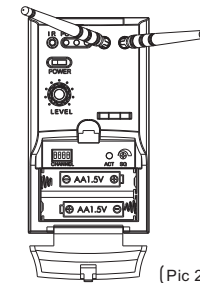

(Pic 2)

Or connect the DC power to the rear DC INPUT jack. (Pic 3)

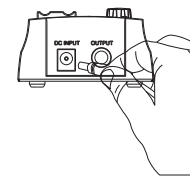

(Pic 3)